



**HKU
Med** LKS Faculty of Medicine
Centre for PanorOmic Sciences
香港大學泛組學科研中心

Imaging and Flow Cytometry Core

Imaging and Flow Cytometry Core
Centre for PanorOmic Sciences

**LSM 900 with Airyscan
Confocal Microscope
Standard Operation Protocol**



Imaging and Flow Cytometry Core

Contents

System Start Up.....	3
ZEN Software Initialization	3
Set the temperature and CO2 control for live cell imaging.....	4
Locating Sample and Finding a Region of Interest	5
Setting up the Scanning Track/Channel.....	6
Confocal Imaging Set Up.....	7
Scanning Parameters Set Up	8
LSM-Airyscan mode Imaging Set Up.....	9
MPLX-Airyscan mode Imaging Set Up	10
Sample Navigator.....	11
Experimental Designer.....	13
Storing and exporting image data.....	14
Z-Stack Experiment Set Up	15
Time Series Experiment Set Up.....	16
Multiple Position Experiment Set Up.....	18
Tile Scan Experiment Set Up.....	19
Turning off the system	20

Imaging and Flow Cytometry Core

System Start Up

Sign on log sheet according to **Actual** start time (**Please leave at least 5 seconds gap in between each step of machine Start Up process**)

1. Switch on Main power switch ① → wait for 5 seconds
2. Switch on Main power switch ② → wait for 5 seconds
3. Switch on System power button ③ → wait for 5 seconds
4. Switch on Components power button ④ → wait for 5 seconds
5. Turn on Standby/On key switch for laser ⑤ from **vertical to horizontal direction** → wait for 5 seconds
6. wait for Focus Controller.2 show **stand by** → Turn on the computer power ⑥

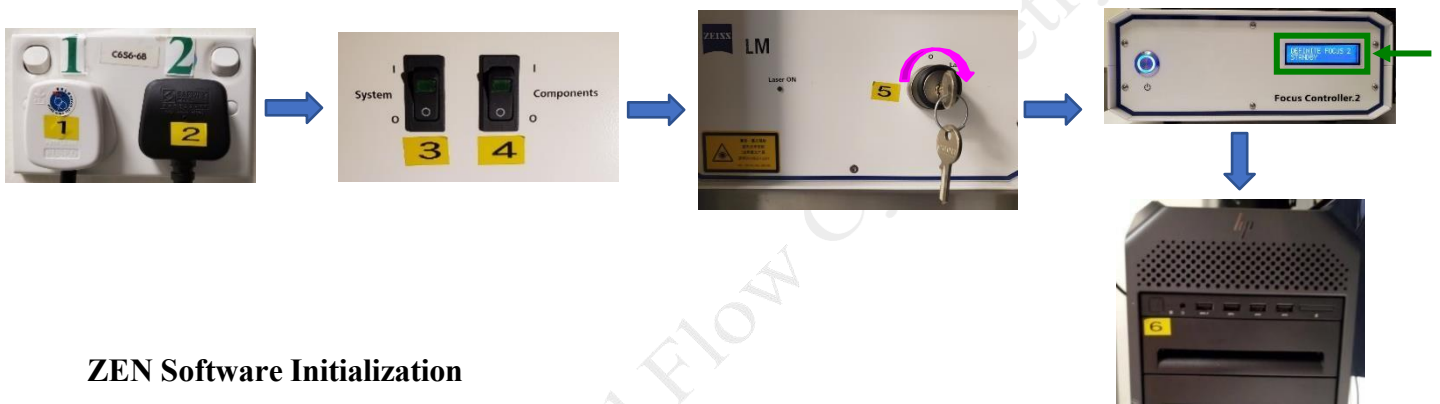

ZEN Software Initialization

1. Log on computer with “USER” account
(Please find **USER account password** posted under the bottom of computer screen)
2. Double click the **ZEN 3.1 blue** icon on desktop
3. Click **ZEN system** to run the software
4. Click **Calibrate Now** to calibrate stage

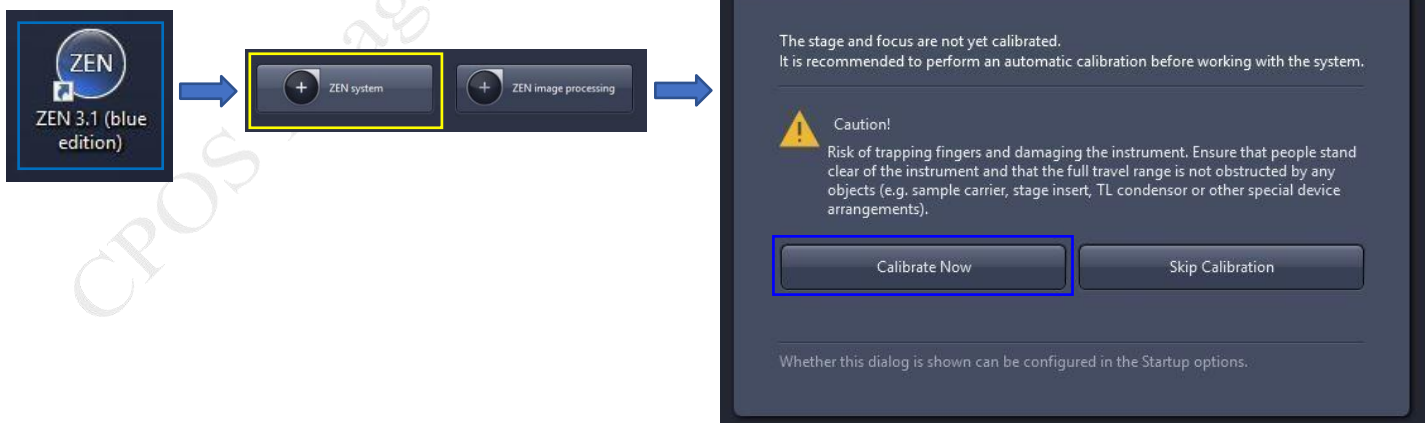

Imaging and Flow Cytometry Core

Only applicable for live cell imaging, please skip this step if it is not needed

Set the temperature and CO₂ control for live cell imaging

- Switch on “**Incubator**” for temperature and CO₂ control.
- Switch on the **Power** of Tokai Hit incubation system controller.
- Temperature can be altered via pressing the green button of each heating parts on the touch screen (Temperature has been set up for live cell imaging. If other temperature is needed, please contact Imaging core staff for temperature alteration)
- Make sure the CO₂ sliding button is turned **ON**.
- Turn on CO₂ tank by turning the main switch **anticlockwise**.
- Turn on CO₂ regulator by turning regulator **clockwise** to set output pressure at 100kPa.
- Put on objective heater on objective if oil objective is used.
- Metal ball floats is an indication of the presence of CO₂ gas flow.
- Add MilliQ water into the water chamber and covered if overnight(s) acquisition is required.

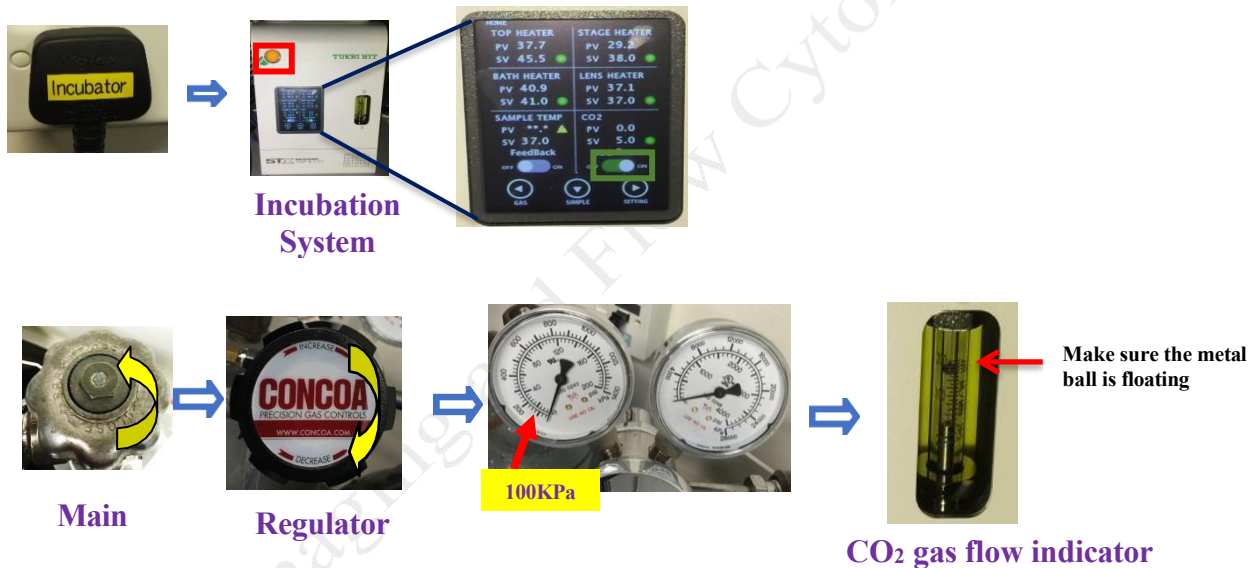

Imaging and Flow Cytometry Core

Locating Sample and Finding a Region of Interest

1. Select a **desired objective** from the touch screen. Apply a drop of oil onto the tip of the lens if 40x oil objective is used.
Never put oil on Air objective!!!(2.5x, 5x, 10x, 20x)
Note: Please make sure there is no oil or water at all on your slide when you are using air objective. Any Oil or water will cause damage to the air objectives)

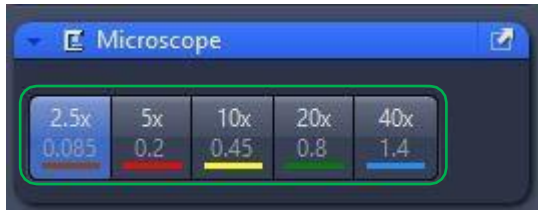

2. Place the sample (slide/dish) on the stage with coverslip facing down.
3. Move the region of interest to right above the objective lens with the **joystick**. Press the **top right button** to change the speed of stage movement (from fast to slow mode or in reverse).
4. Click "**Locate**" tab in the software and select a fluorescent channel of interest for direct observation via the eyepiece.
5. Click **BF** tab to set the microscope for brightfield observation.
6. Click on **Green/Red/Blue/G+R+B/BF** tab for green emission /red emission/blue emission /green+red+blue emission /Bright Field observation respectively.
7. Focus the sample with Coarse/Fine focusing knob.
8. Once the region of interest is found and focused, switch the tab to "**Acquisition**".

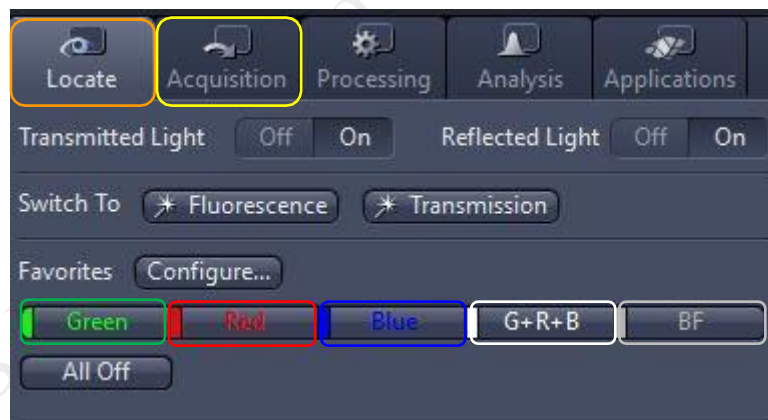



Imaging and Flow Cytometry Core

Setting up the Scanning Track/Channel

Method 1

Load a **predefined configuration** of combination dyes from the **Load configuration list**. Select “OIFC_Confocal” if confocal mode is required.

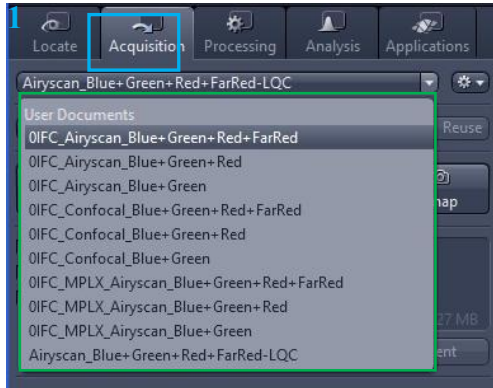

Method 2

Open any previous image with desire click “**Reuse**” button in Dimension panel.



Imaging and Flow Cytometry Core

Confocal Imaging Set Up

1. Select only **one channel** tool for parameter adjustment at a time.
2. Click **Live** for continuous fast scanning.
3. Activate **Range Indicator**. The scanned image appears in greyscale with red pixel indicating saturation (max. intensity) and blue pixel indicating zero (min. intensity). Advise to adjust the laser power and/or gain master until a little bit of red pixel is seen.
4. Set the **Pinhole to 1 AU (Airy Unit)**. For co-localization studies, adjust the pinhole of each channel to the same **Optical Slice Thickness**.
5. To get optimal intensity and background signal,
 - a. Increase **Detector Gain (Maximum of 800)** until a few red pixel (indicating saturation) appear in the image.
 - b. Increase the **Laser Power** (too high cause bleaching), if increasing detector gain cannot achieve the desired intensity.
 - c. Fine-tune the focus with the fine adjustment knob to the brightest or preferred z- position. And then adjust the detector gain and laser power to optimize the signal intensity.
 - d. Decrease the **Digital Offset** to reduce background signal until the desired background region is filled with blue pixel.
 - e. Increase **Digital Gain** to increase signal amplification if needed.
6. **Stop** the Live scan process and uncheck the Range Indicator.
7. Repeat step 1- 6 for other tracks.

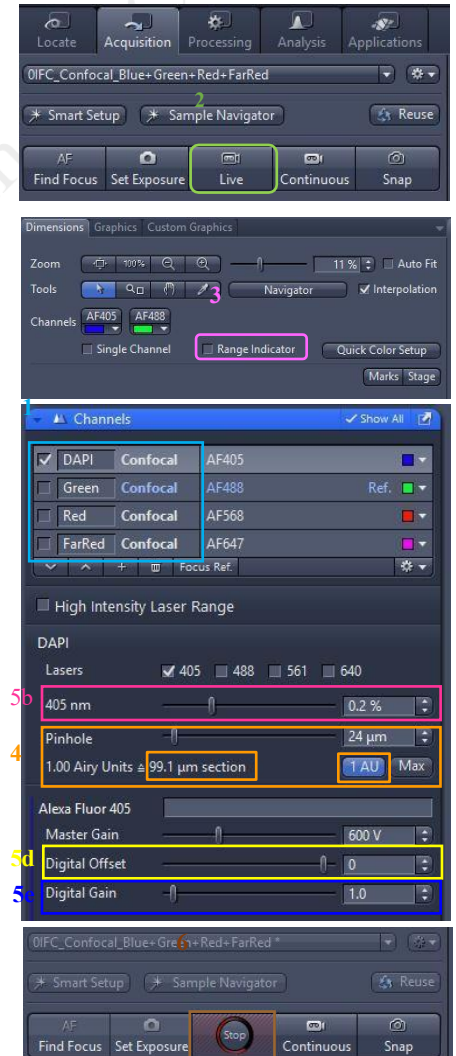

Imaging and Flow Cytometry Core

Scanning Parameters Set Up

1. Go to Acquisition Mode.
2. Select a suitable **Scan Area** to capture image of interest (or use **Crop Area** function after a Live image).
3. Choose a **Frame Size** (change of **Pixel size**, thus change of resolution). 1024x1024 usually produces good results for general purpose. Click on the **Confocal** button for best resolution which depending on objective N.A. and λ .
4. Adjust the scan speed with the **Speed** slider. Speed 4 or 5 usually produce good results. For samples with high background noise, use Speed 4.
5. Select the number of **Average**. Averaging (usually in 2 or 4) improves the image quality by increasing the signal-to-noise ratio but it also increases the scan time.
6. Select the Bits per Pixel of 8 or 16 Bit in the **Bits per Pixel**. 16 Bit is recommended when doing quantitative measurements or other post-analysis.
7. Other setting can be kept as defaults (as in the right) which will be good enough for general purpose.
8. Click **Snap** to acquire a single frame (multi-channel) image.

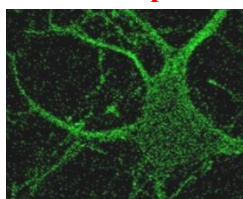
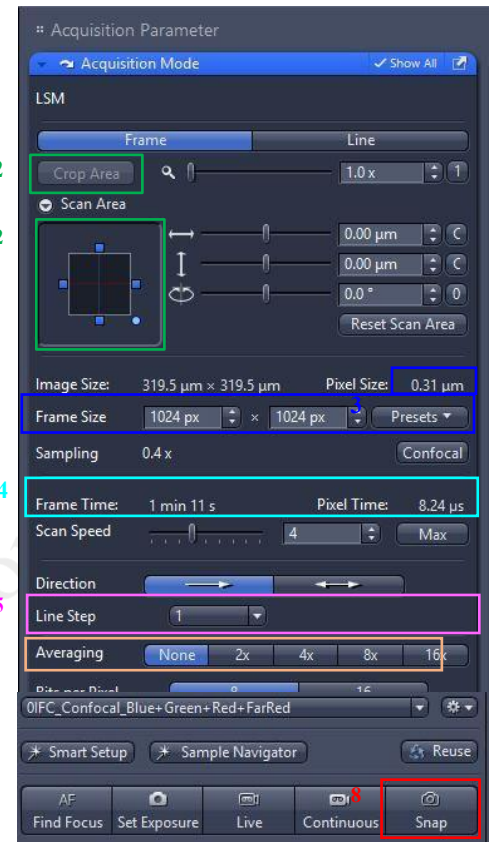

Lower scan speed;
or More averaging

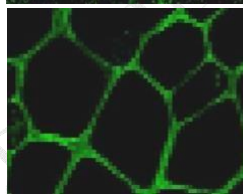
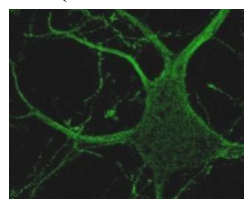

Larger frame size
(Higher resolution)

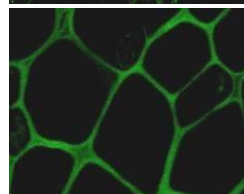

Imaging and Flow Cytometry Core

LSM-Airyscan mode Imaging Set Up

- Once a region of interest is found under the eyepiece → click **Acquisition** → Select a predefined LSM-AiryScan configuration (e.g. **0IFC_AiryScan_Blue Green+Red+FarRed**) of combination from the list. Alternatively, click “**Reuse**” the previous settings by loading an old image file.

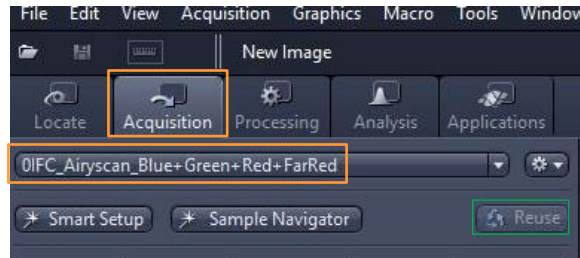

- Select **one channel** of interest at a time → Click **Live** → Click on **AiryScan** tab under Maintain panel → Adjust focus to the best focal plane (**brightest hexagon in the middle**) → Adjust the **laser power and Master Gain** → Check **Quality and Status** in the **AiryScan** tab from **No or too much signal** to **OK** → Click on **Continuous** → Click **AiryScan** → Choose **SR** in the **Display Mode** → Click **display** → Click **Min/Max** → **White range** between 3000 to 8000
- Repeat step 2 for other channels → Choose a **Frame Size** or click **SR** → Click **Snap**.

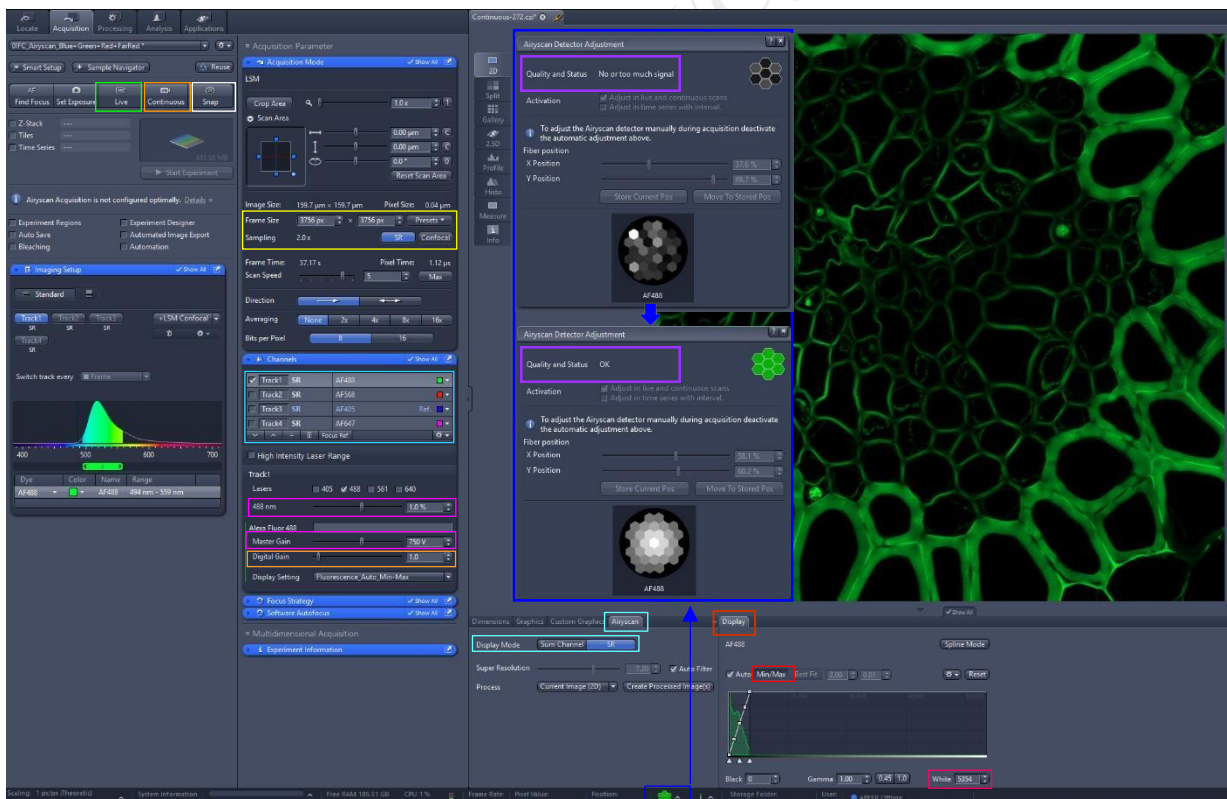

- SR mode:** increased resolution, the Pinhole has no effect and the default position should not be changed.
- Cofocal mode:** set the system for conventional confocal mode, the hardware pinhole is effective and can be set at the required value for confocal sectioning.

Imaging and Flow Cytometry Core

MPLX-Airyscan mode Imaging Set Up

1. Once a region of interest is found under the eyepiece → Click **Acquisition** → Select a predefined MPLX-AiryScan configuration (e.g. **0IFC_MPLX_Blue+Green+Red+FarRed**) of combination from the list.

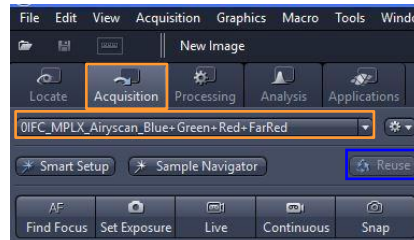

2. Select **one channel** of interest at a time → Click **Live** → Click on **Airyscan tab** under Maintain panel → Adjust focus to the best focal plane (**brightest hexagon in the middle**) → Adjust the **laser power and Master Gain** → Check **Quality and Status** in the **Airyscan tab** from **No or too much signal** to **OK** → Click on **Continuous** → Click **Airyscan** → Choose **SR** in the **Display Mode** → Click **display** → Click **Min/Max** → **White range** between 3000 to 8000 → Repeat same approach for other channels → Click on **SY-2Y/SR-4Y/CO-2Y** → Snap

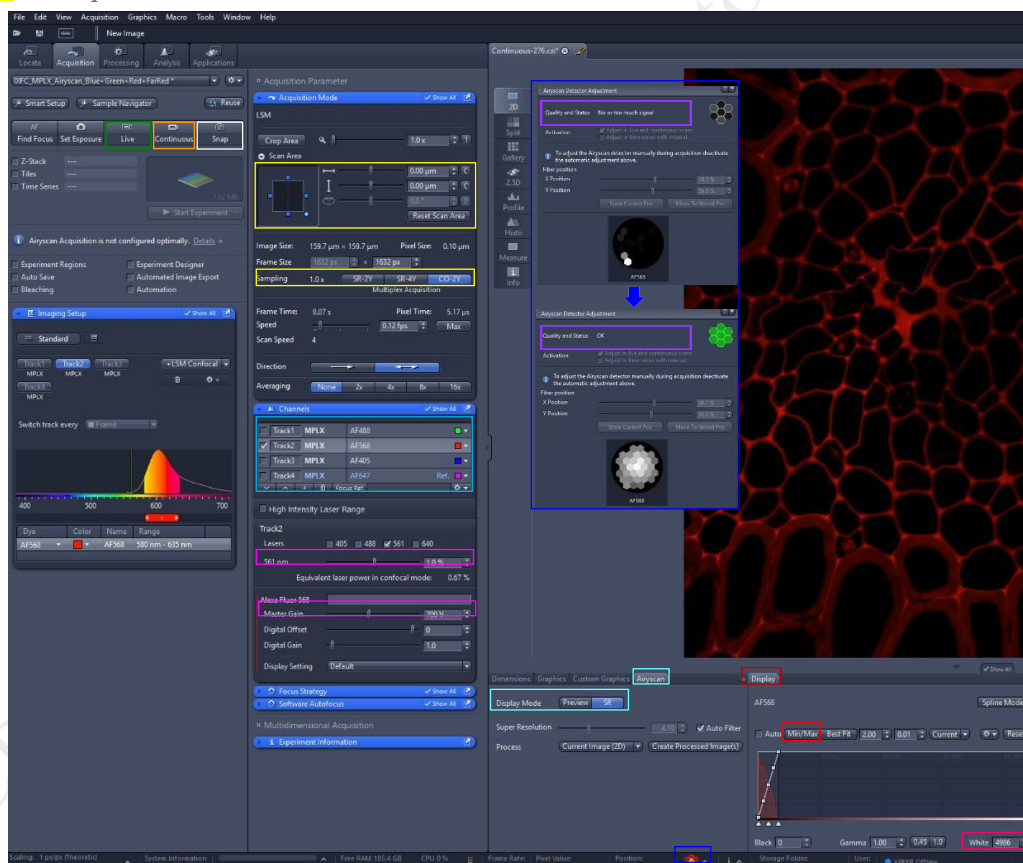

- **SR-2Y** sets the sampling for superresolution imaging with Fast at 2,0x Nyquist sampling. (2x faster than conventional Airyscan SR).
- **SR-4Y** sets the sampling for superresolution imaging with Fast at 2,0x Nyquist sampling. (4x faster than conventional Airyscan SR).
- **CO-2Y** sets the sampling for flexible confocal resolution imaging with Fast at 1.0x Nyquist sampling. (with increased signal-to-noise with Airyscan detector.)

Imaging and Flow Cytometry Core

Sample Navigator

1. Put a sample on the stage and center the sample with some structure over the center of the objective.
2. In the Acquisition tab, click on the **Sample Navigator** button → Select at least one checkbox with the wavelength (405nm/488nm/561nm/640nm) that matches the label of your sample (strongest channel with less photon bleaching is preferred) → Click on **Next**

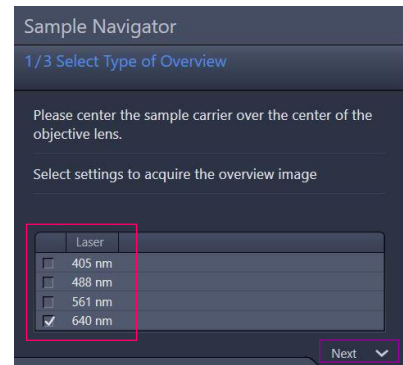
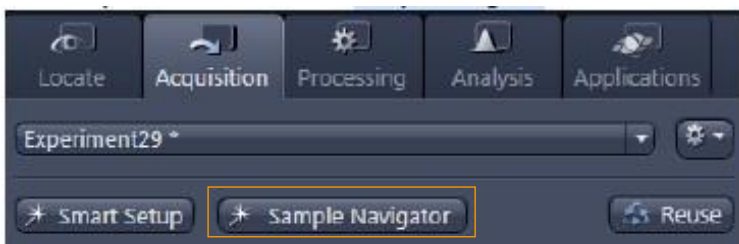

3. Click on **Use current focus** if sample was already focused, or click on **New sample/objective** if a new sample was put on the microscope. With a new sample, you are asked to focus the objective a bit closer than the putative focus plane. This is because the autofocus will move away from the sample when searching for the focus plane. Click on **Objective is now close to the sample** → Click on **Next**, go to step 2.

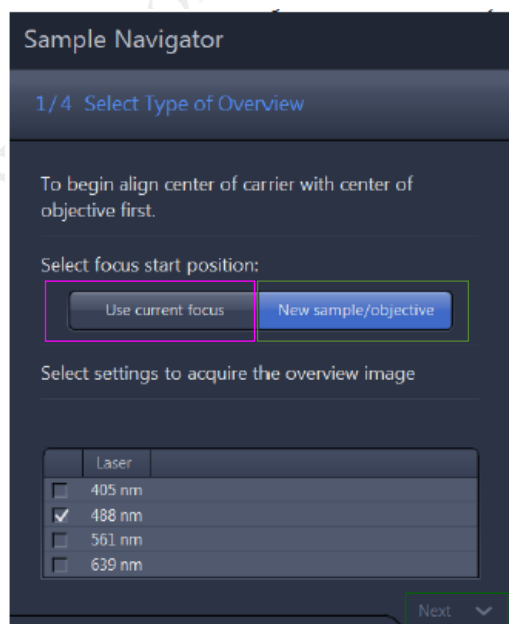

4. Select a matching **sample carrier type** from the selection list in the middle → select the coverage degree **Small**, **Middle** or **Full** (Full means full coverage of the Cover slip area, middle means 1/4 coverage of the Cover slip area, Small means 1/16 coverage of the Cover slip area). The selected coverage is displayed by a **red area** on the sample carrier drawing → Click on **Next** at the bottom of the wizard, go to step 3.

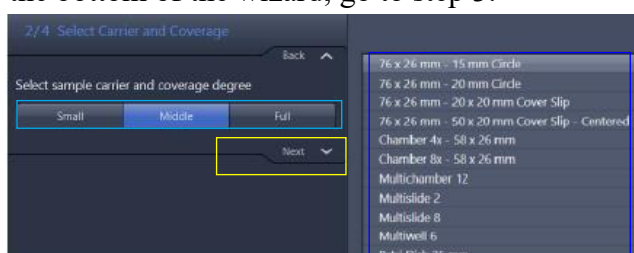

Imaging and Flow Cytometry Core

5. Ensure that the steps listed in the center area are performed: 1. Align the lines on the right side of the condenser carrier. 2. Open apertures. 3. Use the black cloth to protect the sample space from room light. → Click on **Next** at the bottom of the wizard, go to step 4.

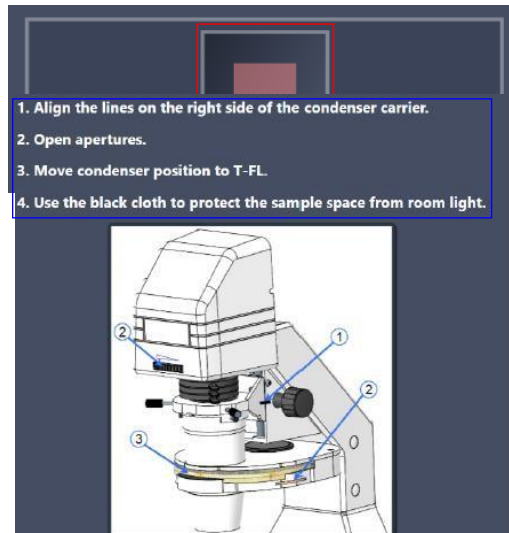
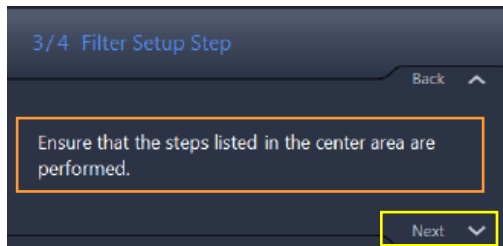

6. Click on **Focus Detection** to start the autofocus, and observe the image in the middle → adjust the light intensity with the slider **Light Source Intensity** if needed → manually focus the sample with the focus drives if needed → Click on **Finish** to start the automatic overview tile scan.

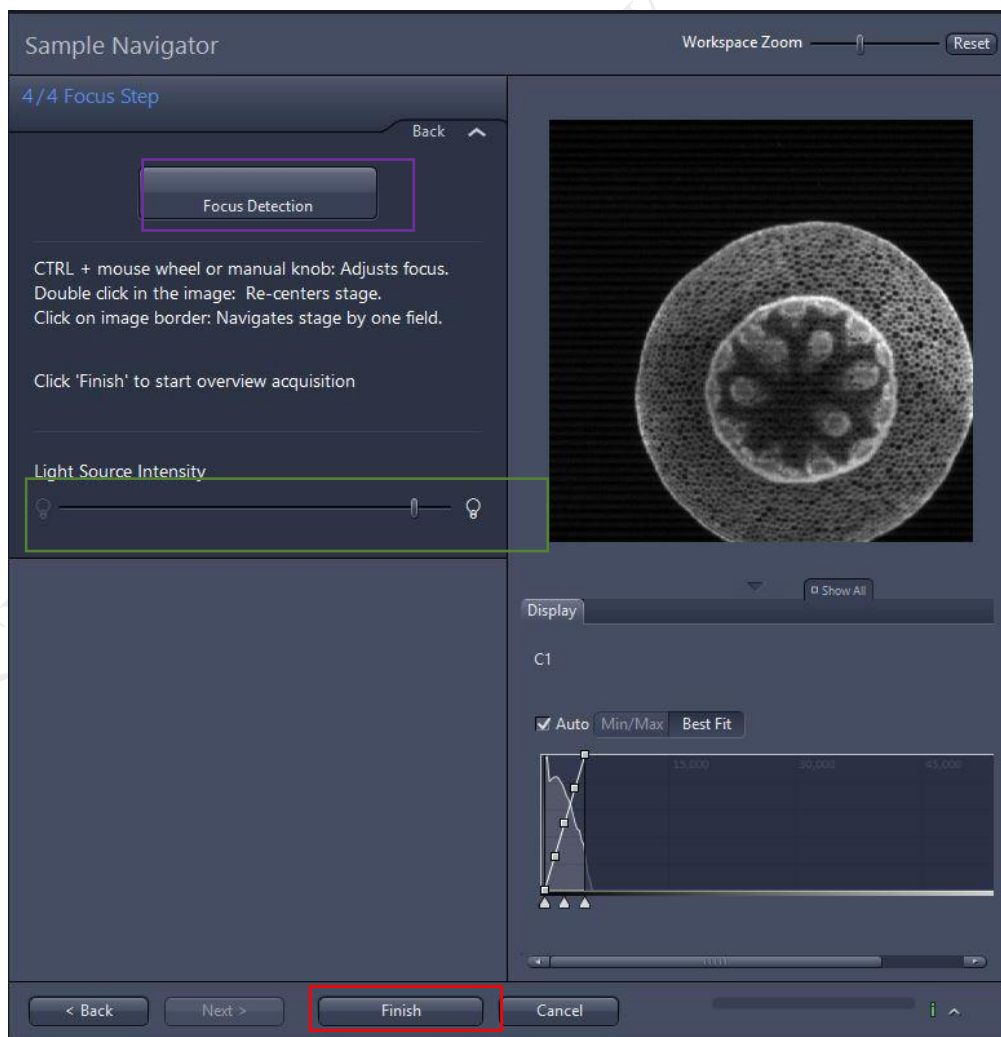

Imaging and Flow Cytometry Core

Experimental Designer

1. Users can use this application if their study involves different multi-dimensional acquisition parameters. Each parameter setting can be assigned to one imaging block.

Tile Scan; Positions; Regions; Bleaching

2. Tick experiment designer → After setting up the acquisition parameters for one block → click “**Create Acquisition block**” to create another block → then change the acquisition parameters accordingly in the second block.

3. You may use the “Loops and Repetitions” function if many rounds of the same sequence of experiment blocks are required.

Expand the “**Loops and Repetitions**” → key in the **required details** → check “**Active**” → click “**Start Experiment**”.

- **Acquisition Block:** image acquisition performed according to the acquisition parameter settings.
- **Delay Block:** sets a time delay between two blocks. The delay time is set using the Delay slider which shows up when selecting a Delay Block (time unit ranging from milliseconds to days).
- **Wait Block:** pauses the acquisition until the user actively confirms the message box.
- **Loops:** states how often a sequence of Blocks defined by the number of the Block in Start and End is run. One loop/repetition is set as default and reflects the minimum of running the experiment once.
- **Two loops:** perform the defined sequence twice. Repeat one Block by choosing the same number for Start and End.
- Whenever a block being part of a sequence is reached, the defined number of loops is performed. Thus outer loops also contribute to the number of total runs of an inner loop.

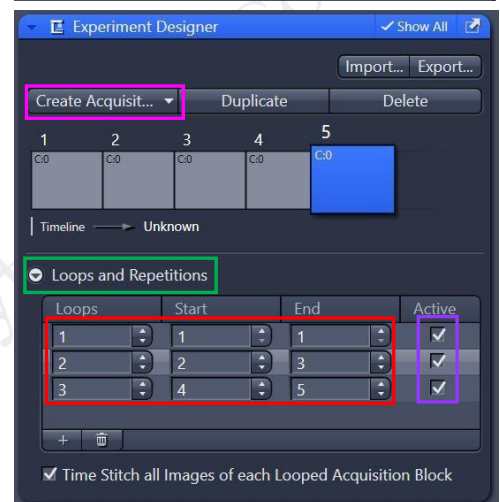
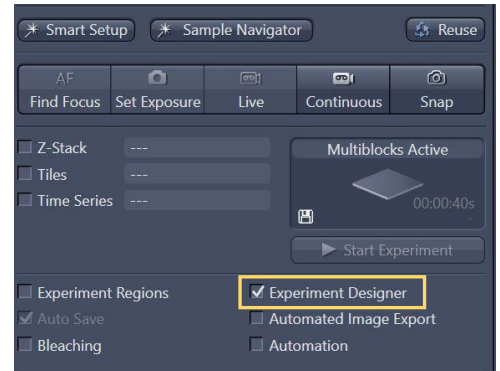



Imaging and Flow Cytometry Core

Storing and exporting image data

1. To save the acquired image → **highlight** the desired image → click on **Save** icon button or Save As button in the File menu → Create or choose your own folder in the D Drive (D:/user). **Warning Icon** indicated unsaved.
2. Create or choose your own folder in D:\user, enter a file name, select format as **CZI** and click on the **Save** button.
3. After saving the raw data as CZI format, Image can be exported as various Image format and series images can be export as video. Go to processing (or Go to File > Export) → Image Export → choose the **File type** as shown below → Choose **export to** → select the image you want to export → click on **Apply**.

File type	JPEG File Interchange Format (JPEG) Windows Bitmap (BMP) Tagged Image File Format (TIFF) Tiff Format(64Bit) (Big Tiff) Portable Network Graphics (PNG) JPEG XR (WDP) DigitalSurf SUR (SUR)
-----------	--

4. For export as video → Go to processing (or Go to File > Export) → Movie Export → choose the **Format** as shown below → Choose **export to** → click on **Apply**.

Series (Gallery of images; Time series movie or 3D animation)	AVI (M-JPEG compression) AVI (uncompressed) AVI (DV) WMF (Windows Media) MOV (H.264) MOV (MPEG4) AVI (MS-Video1)
--	--

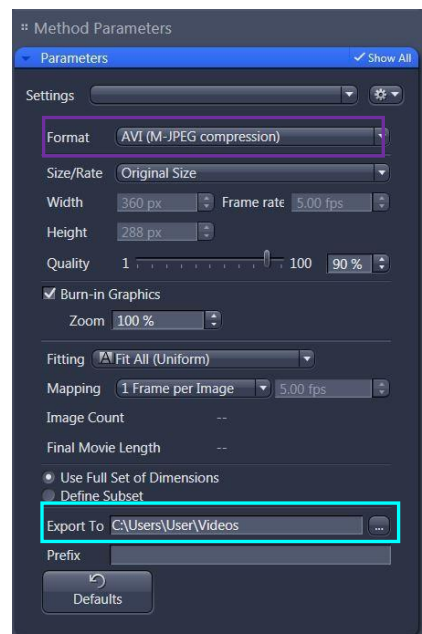
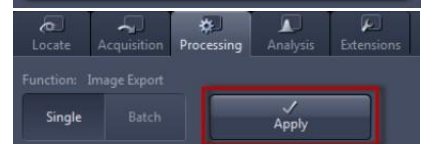
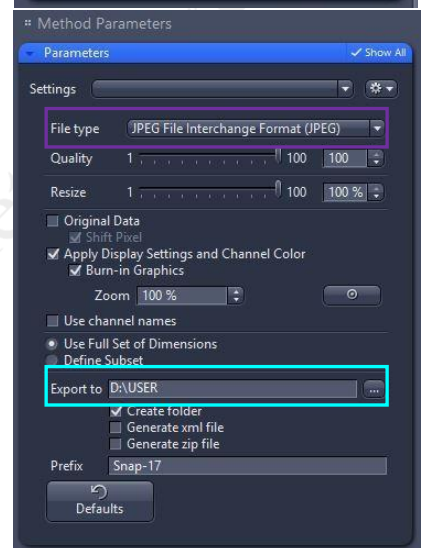
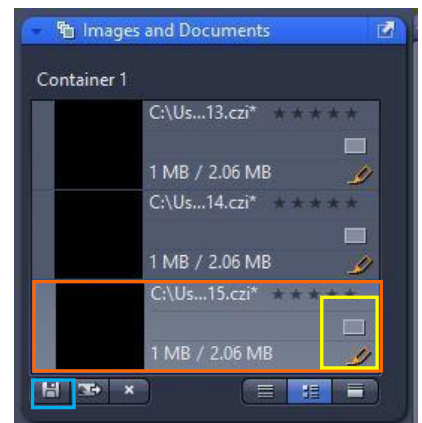



Imaging and Flow Cytometry Core

Z-Stack Experiment Set Up

1. Check the **Box for Z-Stack** → Open the **Z-Stack module**.
2. Choose a channel that has signal throughout the interested volume → start **Live**.
3. Use the focus knob to locate one end of the specimen → **Set First**. Focus to locate another end of the specimen → **Set Last** → stop **Live**.
4. Set the Z-stack **Interval** between each frame equal to or less than the thickness of the thinnest **Optical Section** of the selected channel wavelength (so that you can scan all the space within the specimen). **Optical Section (pinhole)** of the channel is calculated according to the emission wavelength, objective lens, and the pinhole diameter.
Optimal: double sampling with interval equal to half of the thinnest optical section and thus provide better 3D image reconstruction.
5. For colocalization studies, adjust the **Pinhole** of each channel in the Channels panel to the same **Optical Slice thickness** (so that each voxel contains data from the same volume of the specimen).
6. Click **Start Experiment** to start the recording of Z-Stack images.
7. After saving the CZI format, a 2D stack up image can be generated, in which image in all frames will be projected onto a single plane. Go to “**Processing**” tab → choose **Orthogonal Projection** → select **projection plane**, **Method**, set **Start position** and **Thickness** → **Apply**.
8. A video of rotating 3D image can also be made. Activate the **Series** tap, select the **Render Series**, number of frame and the rotation range (= **Total Frame** × **Difference angle**). Click **Apply** and the series images will be generated in a new tab.

Go to File > Export, choose **movie export** and then choose a suitable **series**. Adjust the playing speed by **Frame per Second** and **save** in your own folder.

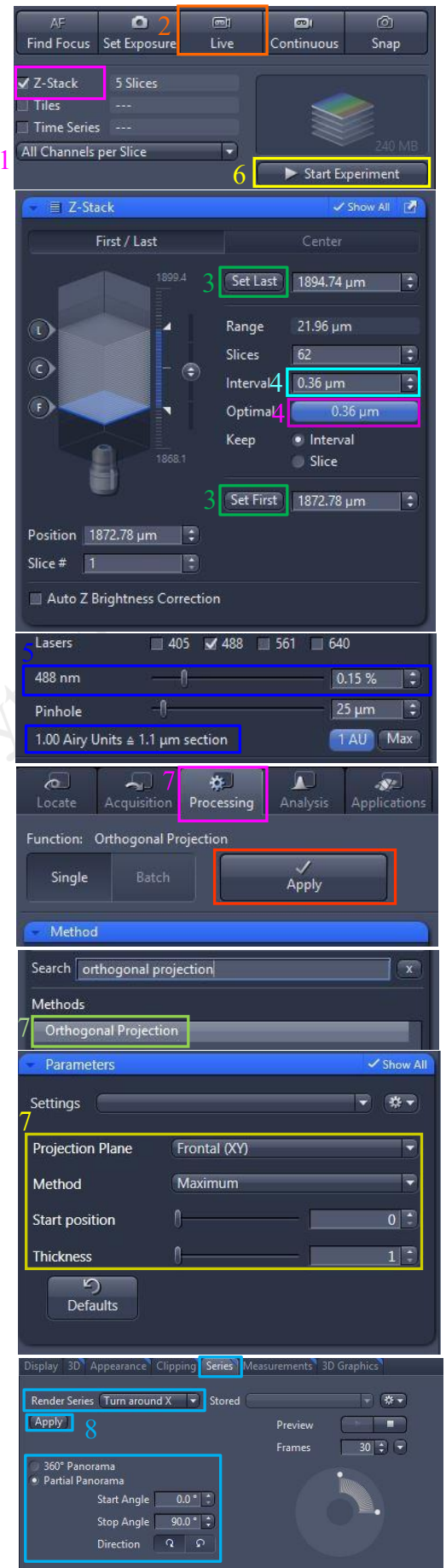

Imaging and Flow Cytometry Core

Time Series Experiment Set Up

1. Check the **Box for Time Series** → open the **Time Series** module.
2. Set the number of **Cycles** and time **Interval** between each frame. (The scanning of each frame is included in the countdown of the Interval, therefore Interval time should be \geq scanning time of one multi-color frame.)
3. Open the **Focus Strategy** to maintain focus stability.
4. Select the focus method in **Focus Strategy**.
 - **None:** No focus strategy has been selected. This is the default setting for all experiments that do not include a tiles dimension. In this case the software automatically selects the Use Focus surface/ Z Values De-fined by Tiles Setup strategy.
 - **Software Autofocus** mode: Identification of the focus reference plane based on the sharpness calculation or intensity calculation of a series of images (Z-stack). (The sample will be scanned for several times to select the best contrast of image. Bleaching may happen due to the multiple scanning. Applicable to fixed sample and live cell with oil objective)
 - **Definite Focus** mode: The Z level of cover glass of sample will be maintained. Applicable to 10x and 20x objective. For 40x objective, only applicable to live cell imaging with medium in petri-dish.
 - a. Step 1: On the microscope touch screen control panel → go to **Home** → **Microscope** → **XYZ** → **Definite Focus**.
 - b. Step 2: Go to ZEN software → Select **Time Series** → select **Definite Focus** mode → go to stabilization Event Repetitions and Frequency → select Standard or Expert (check the box of Time Series and Repeat **Every n Time point** → key in **at which time point** interval you would like the Definite Focus mode to function).
 - **Combine Software Autofocus and Definite Focus mode:** combine the functions of Definite Focus and Software Autofocus. This can be done in two ways,
 - a. **Software Auto-focus as Reference for Definite Focus.** Software Autofocus moves the focus drive to the focus position that has been calculated. Taking this as the starting point, a new reference distance is defined for the next distance stabilization performed by Definite Focus. This can reduce the likely-hood of a stabilization failure when the sample is long and elongated and the carrier possibly tilted.

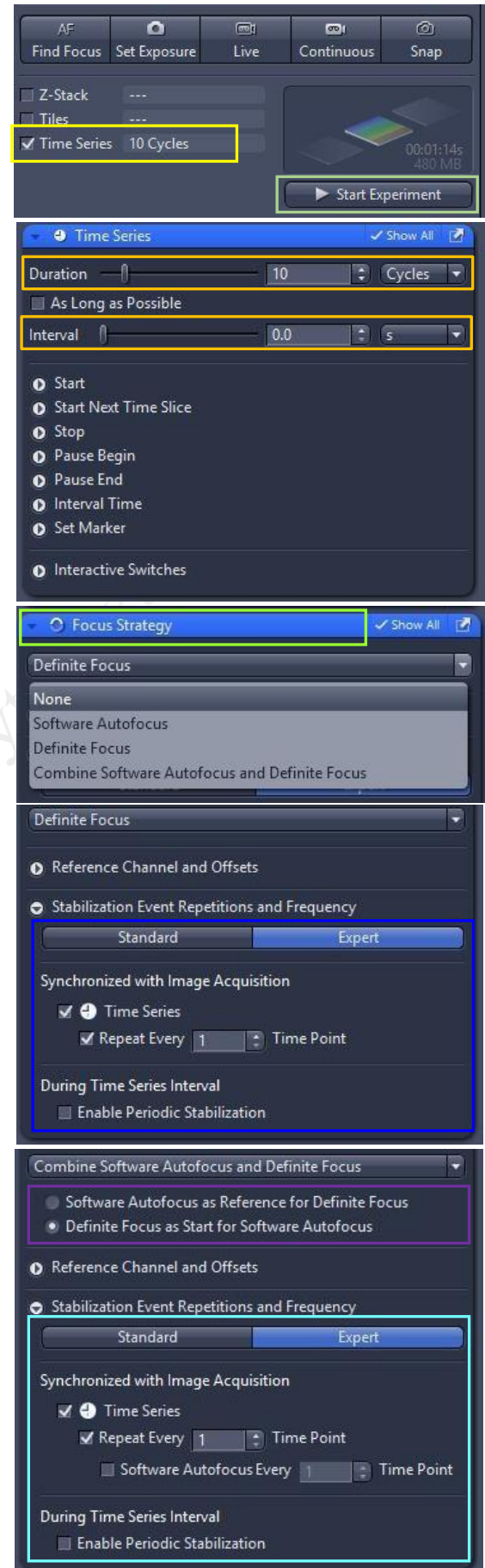

Imaging and Flow Cytometry Core

- b. **Definite Focus as Start for Software Auto-focus.** The last valid Reference Z-Position defined by Definite Focus is the starting position for the Software Autofocus search. This allows you to optimize the search range and step size of Software Autofocus.

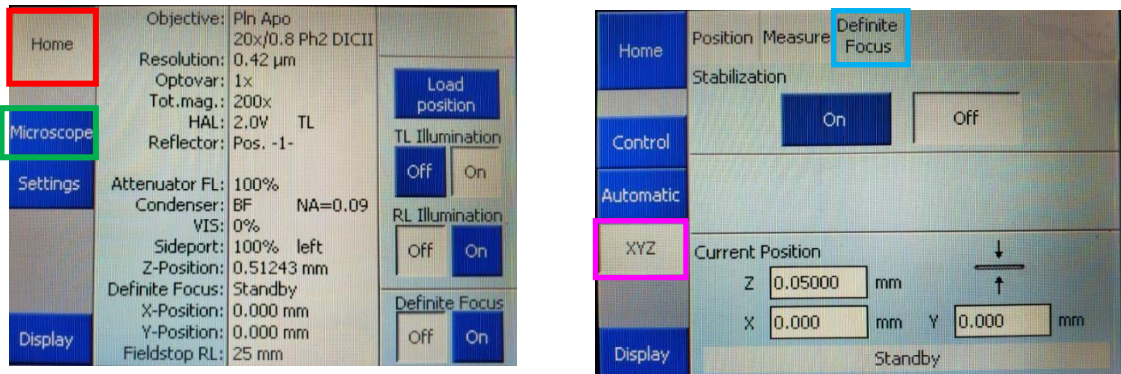

- Set the channel and acquisition parameter if necessary and then click **Start Experiment**.
- To quantifying changes in signal intensity after acquisition, click **Mean ROI** tab and create a **ROI region with the drawing tool** for the region of interest.
- The **intensity profile** along the experiment duration will be shown in the graph while corresponding **data** will be shown in the table right.

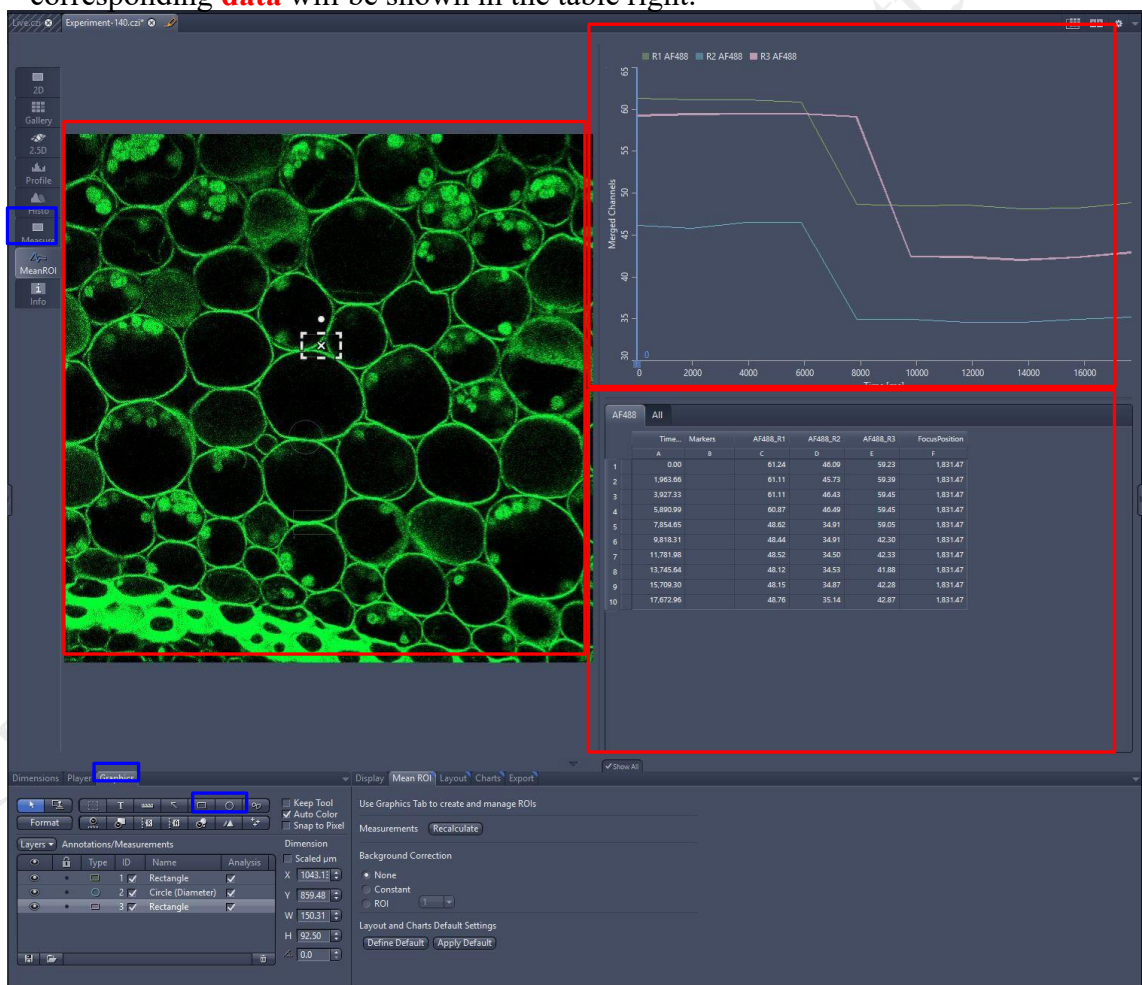

Imaging and Flow Cytometry Core

- After saving the CZI format, video for the time series images can be exported. For export as video → Go to processing (or Go to File > Export) → Movie Export → choose the **Format** as shown below → Choose **export to** → click on **Apply**. Adjust the playing speed by **Frame per Second** and **Select file name and save** in your own folder.

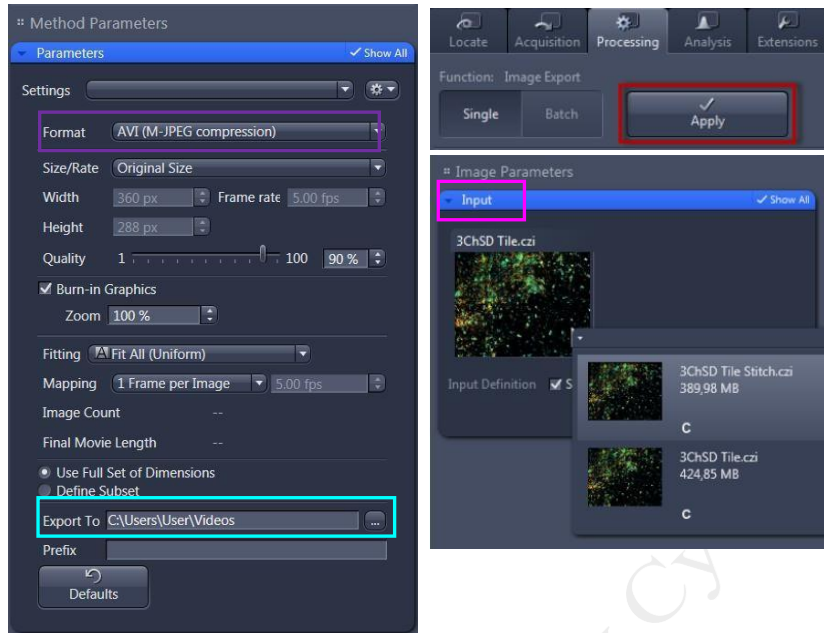

Multiple Position Experiment Set Up

- Open the **Tiles** tool in the Multidimensional Acquisition module and activate the Show all mode.
- In the Tiles tool open the Sample Carrier section → Click on the **Select...** button → Choose a predefined **Sample Carrier template** and click **OK (if applicable)**.
- Open the **Positions** section.
- Start the Live mode to use the stage to locate a position that you want to acquire.
- Bring the specimen into focus using the focus drive.
- Click on the **Add** button → The current **position** is added to your experiment.
- To add further positions, move the stage to another position on the sample and repeat the previous steps. (The added **positions** are shown in the list in the Single Positions section with their X, Y and Z-coordinates.)
- Save the experiment (**if applicable**). To do this, in the Experiment Manager click on the **Options** button and select the Save As entry. Enter a name for the experiment in the input field (e.g. Simple Tile Experiment).
- Click on the **Start Experiment** button.

Imaging and Flow Cytometry Core

Tile Scan Experiment Set Up

1. Open the Tiles tool in the Multidimensional Acquisition module and activate the Show all mode. → Check the Box for **Tiles** Scan → open **Tile scan** module by clicking the **Tile Regions**
2. Choose the **Contour**
3. Set the scan mode with **Tiles, Size or Stake**.
 - a. Tiles: Enter the number of X and Y to define the tile region (Example: X=3 and Y=3 equals to tile region containing 9 tiles)
 - b. Size: Define the size of tile region
 - c. Stake: Adding the area for tile scanning by input the edges of whole tile area. The software will define the total tile number base on the input region.
4. Click on the  **Add** button
5. To add further tile regions, move the stage to another position on the sample and repeat the previous steps. The added tile regions (**TR1, TR2, etc.**) are displayed in the tile regions list.
6. Save the experiment. To do this, in the Experiment Manager click on the Options button and select Save As. Enter a name for the experiment in the input field (e.g. SimpleTile Experiment).
7. Click on the **Start Experiment button**.

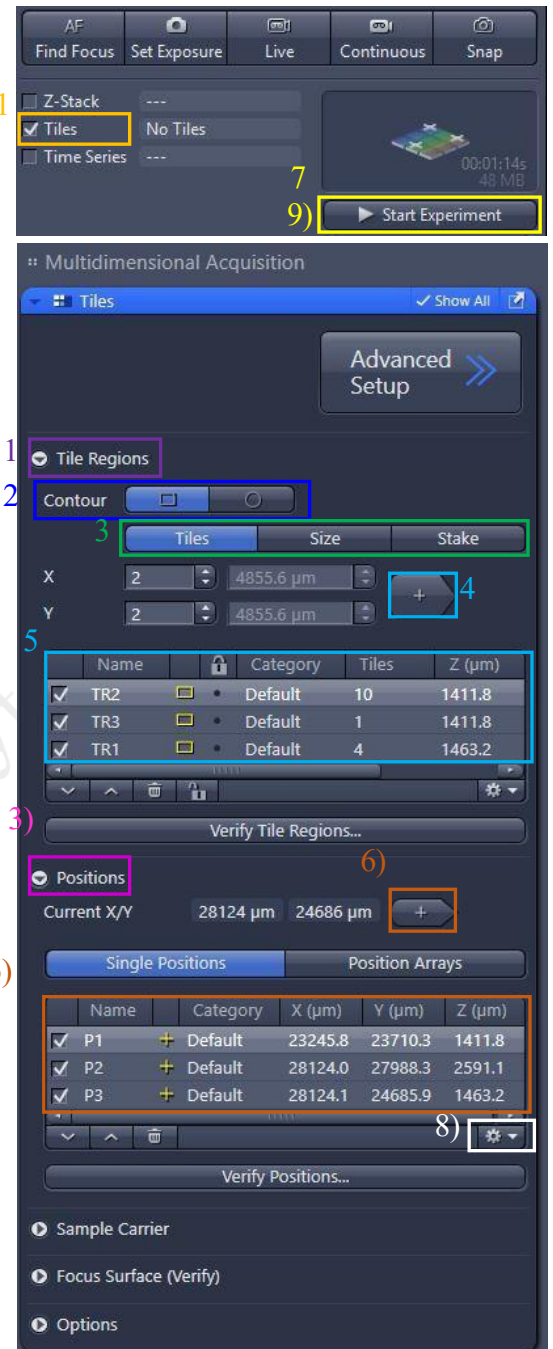

Name	Category	Tiles	Z (µm)
TR2	Default	10	1411.8
TR3	Default	1	1411.8
TR1	Default	4	1463.2

Name	Category	X (µm)	Y (µm)	Z (µm)
P1	Default	23245.8	23710.3	1411.8
P2	Default	28124.0	27988.3	2591.1
P3	Default	28124.1	24685.9	1463.2



Imaging and Flow Cytometry Core

Turning off the system

1. Remove your sample and clean the stage
2. Clean the oil objective (with lens cleaning tissue only but **NOT** Kimwipe).
 - a. Remove immersion oil from the objective lens (40x) with lens cleaning tissue.
 - b. Repeat this step with a new area/piece of the lens cleaning tissue until no oil streaks are seen on the tissue.
3. Remove Objective heater from the objective (**if applicable**).
4. Change objective to lowest magnification (2.5x) objective.
5. Click Load Position (on the touch screen)→Click Set Work Position(on the touch screen).
6. Transfer data through the Imaging and Flow Cytometry Core network storage server.
7. Please check the schedule and switch off the system if it will not be occupied within 1 hr.
(Please leave at least 5 seconds gap in between each step of machine Turn Off process)
8. Shut down PC⑥ → 5 second.
9. Turn the Laser Key (labeled ⑤) 90° counter clockwise for switch off the laser→ wait for 5 second.
10. Turn off the components button④→ wait for 5 second
11. Turn off the System button ③ → wait for 5 second
12. Switch off the Main switch② mounted on the wall→ wait for 5 second
13. Switch off the Main switch① mounted on the wall→ wait for 5 second
14. Turn off the power of incubation system controller and CO₂ regulator and terminate the CO₂ supply (**if applicable**).
15. Sign on log sheet according to **Actual** finishing time.